जलीय तरल पदार्थों को प्रतिधारित करने के
लिए कंक्रीट संरचनाएं — रीति संहिता

भाग 1 सामान्य आवश्यकताएं

(दूसरा पुनरीक्षण)

**Concrete Structures for Retaining
Aqueous Liquids — Code of Practice**

Part 1 General Requirements

(*Second Revision*)

ICS 23.020.10; 91.010.30; 91.080.40

© BIS 2021



भारतीय मानक ब्यूरो
BUREAU OF INDIAN STANDARDS
मानक भवन, 9 बहादुरशाह ज़फर मार्ग, नई दिल्ली – 110002
MANAK BHAVAN, 9 BAHADUR SHAH ZAFAR MARG
NEW DELHI-110002
www.bis.gov.in www.standardsbis.in

FOREWORD

This Indian Standard (Part 1) (Second Revision) was adopted by the Bureau of Indian Standards, after the draft finalized by the Cement and Concrete Sectional Committee had been approved by the Civil Engineering Division Council.

The design and construction methods in reinforced concrete and pre-stressed concrete structures for retaining aqueous liquids are influenced by the prevailing construction practices, the physical properties of the materials and the climatic condition. To lay down uniform requirements of structures for the retaining liquids giving due consideration to the above mentioned factors, this standard has been published in four parts. The other parts in the series are:

Part 2 Plain and reinforced concrete

Part 3 Prestressed concrete

Part 4 Design tables

This standard was first published in 1965 and subsequently revised in 2009. The present revision has been brought out with a view to keeping abreast with the rapid development in the field of construction technology and concrete design and also to bring further modifications in the light of experience gained while applying the earlier version of this standard. In this revision, the title of the standard has been modified from 'Concrete structures for storage of liquids — Code of practice: Part 1 General requirements' to 'Concrete structures for retaining aqueous liquids — Code of practice: Part 1 General requirements' for better representation of the contents of the revised standard.

While the common methods of design and construction have been covered in this standard, for design of structures of special forms, or in unusual circumstances, special literature may be referred to or special systems of design and construction may be permitted on production of satisfactory evidence regarding their adequacy and safety by analysis or test or by both.

In this standard it has been assumed that the design of liquid retaining structures, whether of plain, reinforced or pre-stressed concrete is entrusted to a qualified engineer and that the execution of the work is carried out under the direction of a qualified and experienced engineer.

The concrete used in liquid retaining structures should have low permeability. This is important not only for its direct effect on leakage but also because it is one of the main factors influencing durability, resistance to leaching, chemical attack, erosion, abrasion and frost damage; and the protection from corrosion of embedded steel. The standard, therefore, incorporates provisions in design and construction to take care of this aspect.

The requirements of IS 456 : 2000 'Plain and reinforced concrete — Code of practice (*fourth revision*)' and IS 1343 : 2012 'Prestressed concrete — Code of practice (*second revision*)', in so far as they apply, shall be deemed to form part of this standard except where otherwise laid down in this standard. For long term performance of the structure, use of dense, nearly impermeable and durable concrete, adequate concrete cover without macro defects in cover concrete, proper detailing practices, control of cracking, effective quality assurance measures in line with IS 456 and good construction practices particularly in relation to construction joints should be ensured. Designer should take appropriate measures to the need for chemical resistance while dealing with liquids or sewage/effluents.

Following are the significant modifications incorporated in this revision:

- a) Scope and provisions of the standard have been updated to reflect the applicability of the standard to concrete structures retaining all aqueous liquids.
- b) Design recommendations are generally applicable to the storage/retaining of aqueous liquids having temperature not exceeding 50 °C, and the same has been indicated.
- c) Clause on terminology giving definitions of the various terms has been added.
- d) Clause on 'Exposure conditions' has been modified. Parts of the structure retaining the liquid or enclosing the space above the liquid shall be now considered as subject to at least 'severe' condition as per IS 456. The provision of assuming the underside of the roof to be exposed to 'very severe' condition, for tank retaining chlorinated water, has been added.

(Continued to third cover)

*Indian Standard***CONCRETE STRUCTURES FOR RETAINING
AQUEOUS LIQUIDS — CODE OF PRACTICE****PART 1 GENERAL REQUIREMENTS***(Second Revision)***1 SCOPE**

1.1 This standard (Part 1) lays down general requirements for the design and construction of plain, reinforced or pre-stressed concrete structures, intended for storage or retaining of aqueous liquids. A concrete structure or member may function as liquid retaining, when the amount of liquid permeating through its thickness, under hydraulic gradient, is practically negligible.

The recommendations are generally applicable to the storage/retaining of aqueous liquids having temperature not exceeding 50 °C and no detrimental action on concrete and steel or where sufficient precautions have been taken to ensure protection of concrete and steel from damage due to action of such liquids.

The requirements applicable specifically to plain and reinforced concrete and pre-stressed concrete liquid retaining structures are covered in IS 3370 (Part 2), and IS 3370 (Part 3), respectively.

1.2 This standard does not cover the requirements for concrete structures for storage/retaining of hot liquids, hazardous materials and liquids of low viscosity and high penetrating power such as petrol, diesel and oil. This standard also does not cover dams, pipes, pipelines, tunnels and damp proofing of basements.

This standard does not cover all the requirements of pressurised tanks, floating structures and tanks having the additional requirement of gas tightness. The selection and design of coatings and linings are not covered in this standard.

1.3 The criteria for design of RCC staging for overhead water tanks are given in IS 11682.

2 REFERENCES

The standards given in Annex A contain provisions, which through reference in this text, constitute provision of this standard. At the time of publication, the editions indicated were valid. All standards are subject to revision, and parties to agreements based on this standard are encouraged to investigate the possibility of applying the most recent editions of the standards indicated at Annex A.

3 TERMINOLOGY

For the purpose of this standard, the following definitions shall apply:

3.1 Blinding Layer— A base layer of lean concrete that is laid on the ground to provide a clean, level and dry working surface, sealing in the underlying material and levelling off the surface.

3.2 Capacity — The net volume of liquid, that the structure can hold between the full supply level (FSL) and the lowest supply level (LSL) that is, the level of the lip of the outlet. Gross capacity includes dead storage as well as the quantity of the liquid which may occupy space above FSL, if so specified for design considerations.

3.3 Contraction Joint — A cut, partial or full, constructed by forming, sawing or grooving in a concrete structure to create a weakened plane to regulate the location of crack resulting from dimensional changes being restrained.

3.4 Construction Joint — A joint in the concrete, such as between two successive wall lifts, introduced for convenience in construction at which special measures are taken to achieve subsequent continuity without provision for further relative movement.

3.5 Dead Storage — The volume of liquid in the tank below normal outlet level or lowest supply level (LSL).

3.6 Design Liquid Depth — The full height of the storage/retained liquid which shall include freeboard zone to account for the rise in liquid for the purpose of design or process, whichever is higher.

3.7 Freeboard — The space above FSL measured as a vertical distance from FSL up to soffit of beam supporting the roof slab or dome or the lowest point of roof or up to the overflow level.

3.8 H/t Ratio — The ratio of the liquid head, H (in mm) and the thickness, t (in mm) of the liquid retaining member.

3.9 Joint Filler — A compressible, preformed material used to fill an expansion joint to prevent the infiltration and to provide support for sealants.

3.10 Joint Sealant — An impermeable ductile material that provide a liquid tight seal by adhesion to the concrete throughout the range of movements.

3.11 Kicker — A small concrete step used at the bottom of columns and walls to ensure the correct alignment and location of the columns/walls is maintained between the floor slabs.

3.12 Leakage — The flow of liquid through the concrete member, under hydraulic gradient, from its one face to another. Appearance of only wet patch on concrete surface may not constitute as leakage.

3.13 Lift — Height of concrete between two successive horizontal construction joints in a vertical RCC member.

3.14 Liquid Retaining Structure — Structure member which prevents percolation or loss of liquid flowing through its concrete thickness, such as units of water treatment plants, channels and liquid storage structures.

3.15 Liquid Storage Structure — Structure enclosing the liquid on all sides preventing its loss, such as water tanks.

3.16 Screed Layer — A layer of concrete prepared in profile (other than form-work or shuttering) to provide a firm surface.

3.17 Shear-friction — The shear transfer across an interface, such as construction joint, crack or between the concretes cast at different times.

3.18 Shear Key — An arrangement to allow transfer of shear mechanically through an interface, between two adjoining concrete parts cast at different times.

3.19 Stress Raiser — The condition of external restraint on a member, which increases internal stress as a result of change in strain due to temperature, shrinkage and moisture, in concrete.

3.20 Sympathetic Cracking — Crack produced in a concrete member at a location just adjacent to the movement joint in the adjoining concrete member. The crack opening in first concrete is called as sympathetic to the joint movements.

3.21 Water-bar (Water-stop) — A continuous preformed strip of durable impermeable material embedded in concrete and anchored on the two sides of a joint, designed and constructed such that the passage of liquid through the joint is prevented without incurring any permanent deformation.

3.22 Water Path — The most probable path along which water can travel under hydraulic gradient.

4 MATERIALS

4.1 The materials used in the construction of liquid retaining concrete structures shall conform to the requirements given in IS 456 and IS 1343 for reinforced concrete and pre-stressed concrete members respectively, except where stated otherwise.

4.2 Aggregates

Aggregates conforming to IS 383 shall be used. The use of porous aggregates, such as slag, crushed over burnt brick/tile, bloated clay aggregates and sintered fly ash aggregates shall not be allowed for parts of structure either in contact with the liquids on any face or enclosing the space above the liquid.

4.3 Reinforcement

Reinforcement shall conform to the requirements given in IS 456. Additionally, galvanized bars or bars conforming to IS 13620 and IS 16651 may also be used to have additional protection against corrosion.

4.4 Admixtures

4.4.1 Mineral Admixtures

Mineral admixtures, if used, shall conform to the requirements given in IS 456. For liquid retaining concrete, use of mineral admixtures are advantageous as permeability of concrete reduces by using mineral admixtures.

4.4.2 Chemical Admixtures

Chemical admixtures, if used, shall conform to IS 9103. For liquid retaining concrete, use of chemical admixtures are advantageous to control water-cement ratio, reduce permeability and achieve desired workability.

4.5 Jointing Materials

Joint fillers, water-bars and joint sealants bars shall comply with the requirements given in 12. The jointing materials used shall not have any adverse effect on the quality of liquid to be stored/retained.

5 EXPOSURE CONDITIONS

For the purpose of this standard, parts of the structure retaining the liquid or enclosing the space above the liquid shall be considered as subject to at least 'severe' condition as per IS 456. In case of members exposed to 'very severe' or 'extreme' conditions, the relevant provisions of IS 456 shall apply.

For structures in which chlorine is dissolved in water or break-point chlorination exists, the underside of roof shall be assumed to be exposed to 'very severe' exposure condition, the nascent chlorine being highly corrosive to concrete.

6 CONCRETE

Provisions given in IS 456 and IS 1343 shall apply for reinforced concrete and pre-stressed members respectively subject to the following further requirements:

- a) The concrete shall conform to Table 1.
- b) The cement content excluding mineral admixtures, such as flyash and ground granulated blast furnace slag (GGBS), should not be used in excess of 400 kg/m³, unless special consideration has been given in design to the increased risk of cracking due to drying shrinkage in thin sections, or to early thermal cracking and to increased risk of damage due to alkali silica reactions.
- c) Cement plaster, if applied to internal surfaces of concrete, should not be treated as an alternative to impermeable concrete.

Table 1 Minimum Cementitious Content, Maximum Free Water-cementitious Ratio and Minimum Grade of Concrete

[Foreword, Clause 6 (a)]

Sl No.	Concrete	Minimum Cementitious Content kg/m ³	Maximum Free Water-Cementitious Ratio	Minimum Grade of Concrete
(1)	(2)	(3)	(4)	(5)
i)	Plain concrete	250	0.50	M 20
ii)	Reinforced concrete	350	0.45	M 30
iii)	Prestressed concrete	380	0.40	M 40

NOTES

1 Cementitious content mentioned in this table is inclusive of mineral admixtures mentioned in IS 456 and is irrespective of the grades of cement.

2 For small tanks having gross capacity up to 50 m³ at locations where there is difficulty in providing M30 grade concrete, the minimum grade of concrete may be taken as M25 (with minimum cementitious content as 350 kg/m³). However, this exception shall not apply in coastal areas, or the area where air pollution is high, or liquid retained is aggressive like sewage.

7 DURABILITY

7.1 The provisions for durability shall be followed as specified in IS 456 for plain and reinforced concrete structures, and as per IS 1343 for pre-stressed concrete structures unless specified otherwise in this standard.

7.2 Special attention is needed where chlorinated water is retained by concrete. Roof members over chlorinated water may need protective coating (anti-chlorine treatment). Presence of other gases (like, hydrogen sulphide) may also require suitable coatings.

7.3 Nominal Cover to Reinforcement

The minimum nominal cover to all reinforcement shall be as per IS 456 for relevant exposure conditions.

8 SITE CONDITIONS

The following siting conditions should be considered during the design and construction of the liquid retaining structure:

- a) Physical characteristics of soil in which the liquid retaining structure may be partly or wholly enclosed and also the physical and geological features of the supporting foundations such as:
 - 1) *Earth pressure* — Allowance should be made for the effects of any adverse soil pressure on walls, according to the compaction and/or surcharge of the soil and the condition of the structure during construction and in service. No relief shall be given for beneficial soil pressure effects on the walls of liquid retaining structure in the container full condition.
 - 2) *Settlement and subsidence* — Geological faults, mining, earthquakes, and existence of subsoils of varying bearing capacities may give rise to movement or subsidence of supporting strata which may result in serious cracking of structure. Special considerations should be given in the preparation of the design, to the possible effect of subsidence or movement of the foundation strata for example, subdivision of the structure into smaller compartments and provision of joints to outlet pipes and other fittings. Joints in structures in mining subsidence areas will need special consideration to provide for extra movement.
- b) *Chemical properties of the soil and of the ground water* — Chemical analysis of the soil and ground water is essential in cases where injurious soils are expected to exist, as concrete structure may suffer severe damage in contact with such soils. Where concrete is likely to be exposed to sulphate attack, requirements specified in IS 456 shall be followed. An isolating coat of bituminous or other suitable materials may be provided.
- c) *Extent of floatation at the site* — If in the siting of a liquid retaining structure, water-logged ground cannot be avoided, the danger of the external water pressure shall be carefully guarded against by the following:
 - 1) Designing the structure to resist such pressure under empty or partially empty conditions and taking precautions to prevent floating (uplift) and ensuring stable equilibrium under all

conditions of internal and external loads. The stability of the structure should be checked against uplift using a factor of safety of 1.25. Overall uplift force shall be estimated as the volume of ground-water displaced by the structure.

Where uplift force acts on unsymmetrical structure, the loss of stability may be due to tilting or rotation. In such a case, factor of safety should be not less than 1.4 against rotational stability.

Consideration should be given to uplift force due to water entering the sides of tank (a transient condition) as a result of heavy rains, even if ground water table may be below the tank.

- 2) Providing effective drainage to reduce the level of external water.
- 3) Providing relief valves discharging into the liquid retaining structure when the external pressure exceeds the internal pressure; this arrangement is feasible only in cases when the liquid retaining structure is not required for the storage of liquids which should not be contaminated.
- 4) Designing both internal and external faces of the walls and floor as water retaining faces, where the walls and floors of the liquid retaining structure are submerged in water or water bearing soils.
- 5) Considering the possibility of sudden change in ground water table or pore pressure in soil or sudden accumulation of water in ground, even for small periods due to heavy rains, in the design.

9 CAUSES AND CONTROL OF CRACKING

9.1 Causes

9.1.1 *Effects of Applied Loads*

Direct or flexural tension in concrete arising from applied external service loads, temperature gradients due to solar radiation, or retaining the liquids at temperatures more than ambient temperature, may cause cracking in the concrete.

9.1.2 *Temperature and Moisture Effects*

Changes in either the temperature of the concrete and reinforcement or the moisture content of the concrete causes dimensional changes which, if resisted internally or externally may cause cracking in the concrete. The distribution and width of such cracks may be controlled by reinforcement, together with the provision of the movement joints.

Heat is evolved as cement hydrates, and the temperature will rise for a day or more after casting and then fall. Cracking usually occurs at this time, while the concrete is still weak. Subsequent lower ambient temperature and loss of moisture when the concrete is mature will open these cracks although the loss of moisture at the surface under external drying conditions is usually low. A structure built in the summer but not filled or an external structure standing empty will usually be subjected to greater drops in temperature than the same filled structure.

9.2 Methods of Control

9.2.1 Plain concrete liquid retaining structures or members may be designed by allowing direct tension in plain concrete, the permissible tensile stress for M20 and M25 concrete being 1.2 N/mm² and 1.3 N/mm² for direct tension and 1.55 N/mm² and 1.75 N/mm² for flexural tension respectively. The gross capacity of such tanks made of plain concrete shall not exceed 25 m³. However, nominal reinforcement in accordance with the requirements given in IS 456 shall be provided for plain concrete structural members.

9.2.2 The most important factor affecting drying shrinkage is the amount of paste (water + cementitious matter) per unit of concrete. Water may be reduced by use of both plasticizing admixtures and by using minimum amount of cementitious material, consistent with quality. The concrete mix should have the largest practical coarse aggregates (compatible with detailing and good workmanship) as this will reduce the cement content. To reduce shrinkage, total cementitious content should be as low as possible while meeting the strength requirements and those given in Table 1.

9.2.3 Cracking may be controlled by avoiding or reducing the gradient of steep changes in temperature and moisture of the concrete, especially during early ages by,

- a) curing the structure/members for a period not less than 14 days.
- b) keeping structures and thin sections below FSL damp, during construction.
- c) covering the concrete surface by plastic/polyethylene or tarpaulin sheet to protect the surface from drying.
- d) reducing the restraints on the free expansion or contraction of the structure by providing a sliding layer when long walls or slabs are founded at or below ground level.

9.2.4 Structures may be provided with movement joints if effective and economic means cannot otherwise be taken to avoid unacceptable cracking.

9.2.5 In making the calculations either for ascertaining the expected expansion or contraction or for strengthening the concrete section, the coefficient of expansion of concrete shall be in accordance with the provisions given in IS 456.

9.2.6 Cracking of concrete can be controlled, to some extent, by filling the tank slowly for the first time. The rate of filling shall be nearly uniform and not more than 1.2 m per 24 h.

9.2.7 Whenever development of cracks or overstressing of the concrete in tension cannot be avoided, the concrete section should be suitably reinforced. Correct placing of reinforcement bars, use of deformed bars, closely spaced bars and use of small size bars lead to diffused distribution of cracks, and hence are preferred practices.

9.2.8 Crack control in ground supported tanks may be done in following two ways:

- a) *A combination of external restraint and reinforcement* — If along the length of member, restraint is continuous, the crack spacing will be small and probable crack widths are finer. For ground supported tanks, continuous external restraint is offered by the friction due to roughness between structural member and ground. However, such restraint may not be uniform along the length and hence, partial internal restraint is to be provided by reinforcement. For construction without joints, satisfactory control over cracking may be obtained by increasing the reinforcement, which provides internal restraint. Requirement of reinforcement increases as the length increases more than 20 m. The reinforcement calculated as per the crack width requirements shall be provided.
- b) *A combination of movement joints and reinforcement* — To economize reinforcement, movement (or partial movement) joints are introduced. For joints to accommodate the movement, external restraint is to be reduced by providing a separation layer between structural member and ground support. To allow slip between structural layer and supporting material below (lean concrete), the top surface of this supporting material shall be in plane and smooth, which normally is achieved by float finish.

Usually bottom surface of tank floor is not plane. Floor is provided with slopes, pockets and extra thickness at different places. All these restrict the possible movement, and therefore positions of these features govern the locations of the movement joints. For each panel between successive movement joints, the bottom surface of structural concrete (floor slab) should be plane.

With introduction of joints, the requirement of reinforcement is to be estimated as per 11.3 and Annex A of IS 3370 (Part 2).

9.2.9 Structural Fibres

Structural fibres, such as steel, may be added to improve performance of concrete during the service life with respect to the following parameters:

- a) Ductility,
- b) Toughness and impact resistance,
- c) Flexural and tensile strength,
- d) Crack propagation, crack width and spacing, and
- e) Fatigue and post cracking behaviour.

The designer shall, however, ensure the improvement in performance before considering the use of fibres in concrete by duly testing or findings based on experimental research.

10 STABILITY OF THE STRUCTURE

Stability of the structure shall be checked as per the provisions of IS 456, except where stated otherwise. The equilibrium and safety of structure and parts of it against sliding and overturning, especially when the structure is founded on a side of long or sloping ground, shall also be checked. In combination with earthquake induced forces, the resistance to sliding is important for sloping terrain.

A structure subjected to underground water pressure shall be designed to resist floatation [as given in 8 (c)] and requirements given in 10.1 and 10.2.

10.1 Overturning

The stable equilibrium of a structure as a whole against overturning shall be ensured so that the restoring moment shall not be less than the sum of 1.4 times the maximum overturning moment due to the characteristic dead and imposed load and 1.2 times the maximum overturning moment due to the characteristic wind/seismic action. Restoring moment due to imposed loads shall be ignored. Restoring moment due to earth pressure should consider only active earth pressure with factor of 1.

To ensure the safety against overturning, stability shall be checked for the load factors for earth pressure, liquid load and uplift taken as 1.6, 1.0 and 1.4, respectively. Liquid load in tank shall be taken as the most critical value between empty to full capacity.

10.2 Probable Variation in Loads

To ensure stability at all times, probable variations in dead load, liquid load and earth pressure during construction, repair or other temporary measures shall be taken into account.

11 DESIGN, DETAILING AND WORKMANSHIP OF JOINTS

11.1 The joints should be minimized or avoided, as far as possible, in liquid retaining structures. Joints are source of weakness and leakages, and also need periodic maintenance during the service life. The recommendations about movement joints (expansion and contraction type) pertain to ground supported or underground structures. For elevated tanks, movement joints are usually not required as the restrains for temperature shrinkage movements are far less compared to ground supported tanks.

Joints are designed to control the occurrence of random cracking, which otherwise will require much higher amount of reinforcement to control the cracking. The positions and details of all the joints proposed in a structure, should be checked and specified by the designer. The joints shall be placed at accessible locations to permit inspection and maintenance as the material of the joints and sealants usually have a smaller life compared to the rest of the concrete structure and hence need periodic replacement to prevent leakage.

Concreting shall be, however, carried out continuously between the joints.

11.2 Joints may be categorized as follows:

a) *Movement joints* — A movement joint is intended to accommodate relative movement between adjoining parts of a structure, with the special provisions made to maintain the water tightness of the joint. Water-bars shall be provided in the movement joints, wherever required. Following are the three main types of movement joints:

1) *Expansion joint* — A movement joint which has no restraint to linear movement and is intended to accommodate either expansion or contraction of the concrete. There is complete discontinuity in both reinforcement and concrete (*see* Fig. 1). An expansion type water-bar shall be provided either centrally in a wall (*see* Fig. 1A) or on the soffit of the floor (*see* Fig. 1B). A centre bulb water-bar may be used in walls. Water-bar may be provided on a liquid retaining face of the member, and in such case water-bar is to be fixed to the sides through proper detailing.

In general, such a joint requires the provision of an initial gap (of the order of 15 to 25 mm) between the adjoining parts of a structure

which by closing or opening accommodates the expansion or contraction of the structure. The design of the initial gap should provide for the expected movement and the permissible compressibility and extensibility of filler and sealing materials.

Design of the joint so as to incorporate sliding surface, is not, however, precluded and may sometimes be advantageous. Usually, a relative displacement is allowed in the plane of the members (perpendicular to the joint). All other possible displacements, such as out-of-plane movements, shall be restrained through external restrains or the use of dowels (*see* Fig. 1C).

2) *Contraction joint* — A movement joint with a deliberate discontinuity but no initial gap between the concrete on either side of the joint, the joint being intended to accommodate contraction of the concrete.

A distinction should be made between a complete contraction joint (*see* Fig. 2) and a partial contraction joint (*see* Fig. 3). In a complete contraction joint, both concrete and reinforcing steel are interrupted and in a partial contraction joint, only the concrete is interrupted, the reinforcement continues across the joint. While the complete contraction joints are not restrained to movement and are intended to accommodate only contraction of the concrete, the partial contraction joints provide some restraint but are intended to accommodate some contraction of concrete.

A water-bar shall be provided either centrally in a wall (*see* Fig. 2A and Fig. 3A) or on the soffit of the floor (*see* Fig. 2B and Fig. 3B). To cater for shear across the face, a shear key may be provided. In a partial contraction joint, a water-bar may be provided, if necessary, preferably centrally in a wall or on the soffit of a floor. Dowels may be provided to resist shear at concrete interface.

An induced contraction joint is a type of partial contraction, where the concrete is cast as continuous. While casting concrete, a groove is created by inserting a strip or preformed water-bar. The groove induces the development of a crack at that location. Arrangements shall be made to seal the groove to prevent leakage through the joint (*see* Fig. 4)

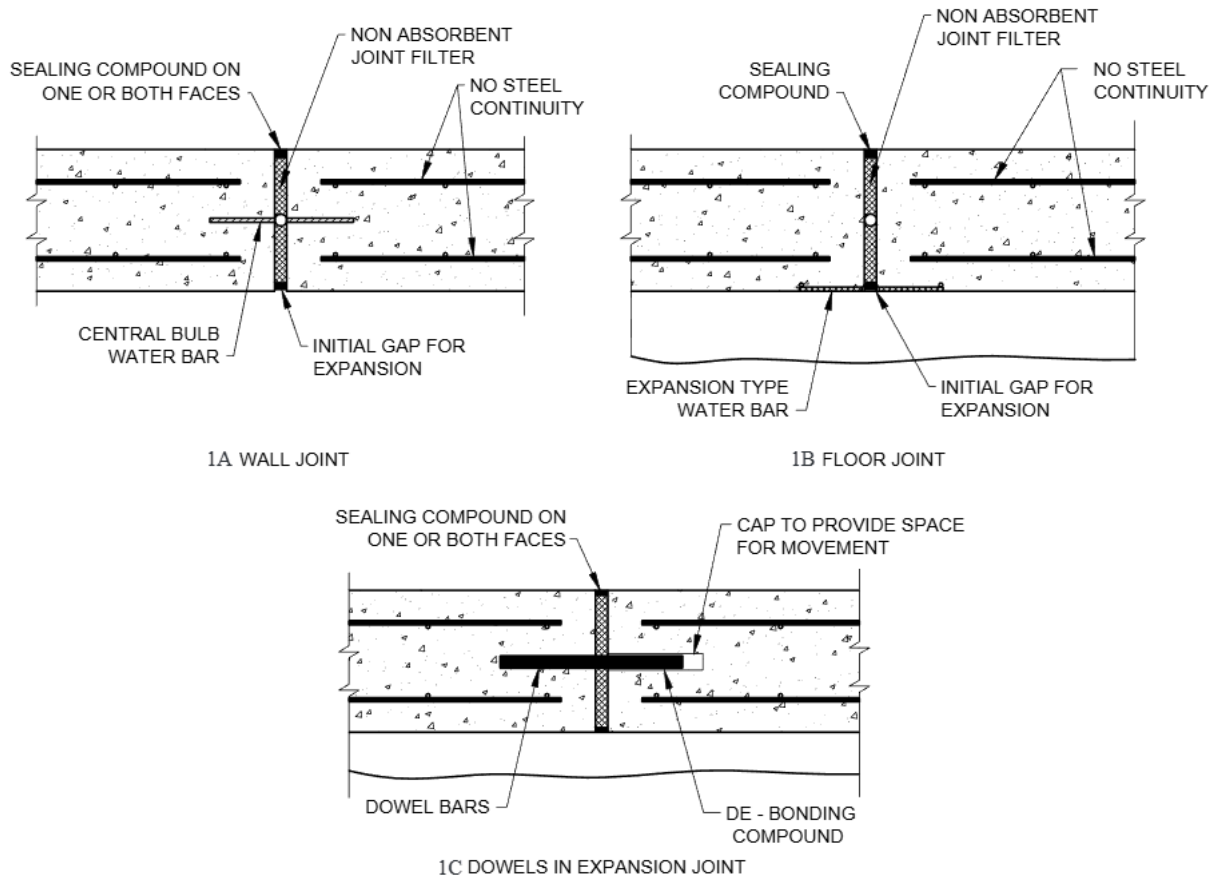

FIG. 1 TYPICAL EXPANSION JOINT

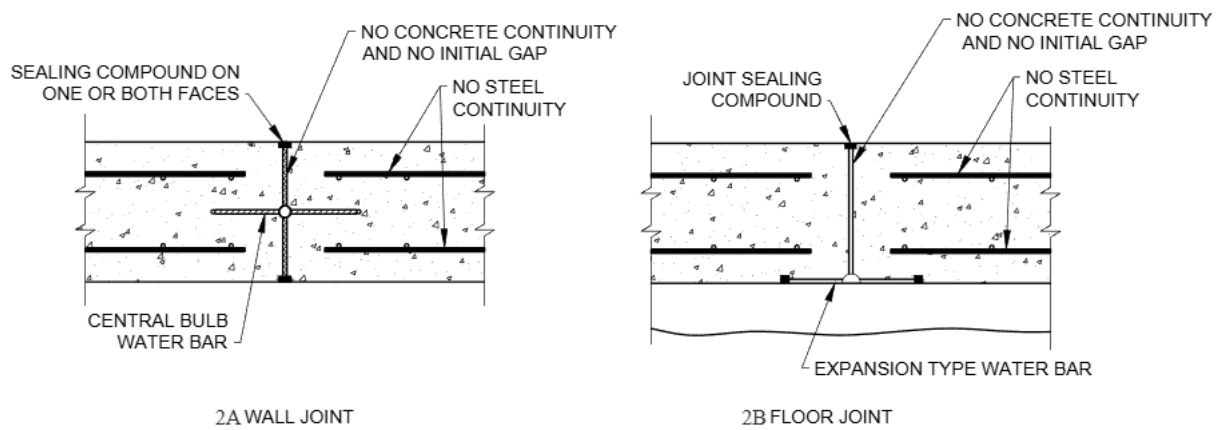

FIG. 2 TYPICAL COMPLETE CONTRACTION JOINT

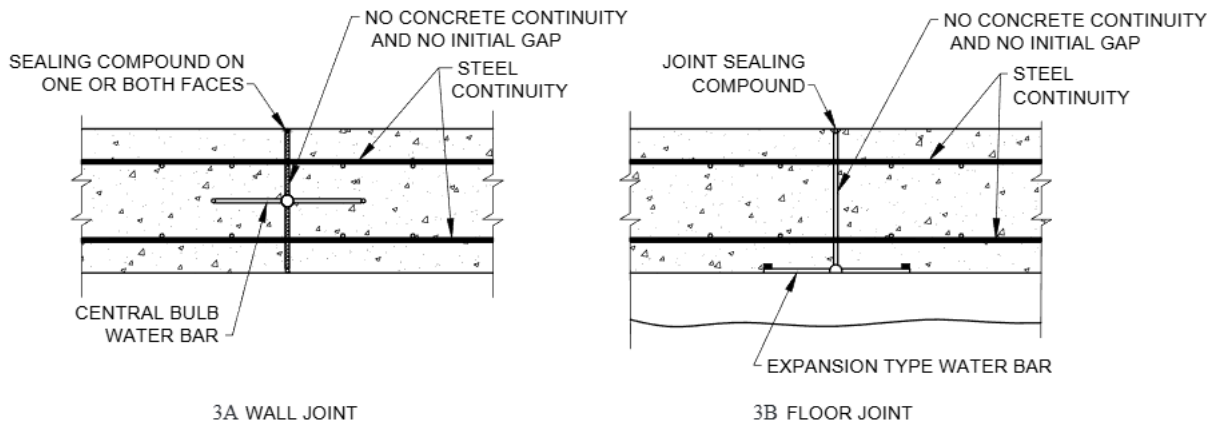

FIG. 3 TYPICAL PARTIAL CONTRACTION JOINT

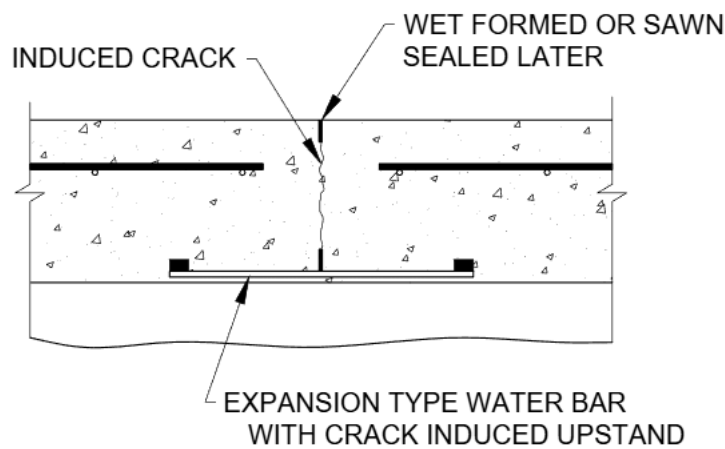

FIG. 4 TYPICAL INDUCED CONTRACTION JOINT IN FLOOR

- 3) *Sliding joint* — A movement joint which allows two structural members to slide relative to one another with minimal restraint. This has complete discontinuity in both reinforcement and concrete at which special provision is made to facilitate relative movement in the place of the joint. A typical application is between wall and floor in some cylindrical tank designs (see Fig. 5).
- b) *Construction joints* — A joint in the concrete, such as between two successive wall lifts, introduced for convenience in construction at which special measures are taken to achieve subsequent continuity without provision for further relative movement. A typical construction joint provided between successive wall lifts is shown in Fig. 6.

In general, construction joints should be provided within middle third of the clear span, preferably near the point of contraflexure [see 4.4.2 (b) and (c) of IS 3370 (Part 2)]. At construction joint, concrete section should be checked under direct shear for shear friction resistance. In slabs, construction joints shall not be provided along the main reinforcement bar.

Full structural continuity is assumed in design at the construction joint and should be realized in practice. If necessary, construction joints should be grouted.

Shear key at the construction joint is normally not required, unless the shear stress is higher than half the shear strength of concrete. If shear key is required to be provided, width or thickness of the member shall be at least 300 mm.

It is not necessary to incorporate water-bars in properly executed construction joint, unless H/t ratio is more than 15 (see 11.5.1). If water-bar is required to be provided, the thickness of member shall be at least 250 mm.

- c) *Temporary open joints* — A gap temporarily left between the concrete of adjoining parts of a structure which after a suitable time interval and before the structure is put into use, is filled with concrete either completely (see Fig. 7A) or as provided below, with the inclusion of suitable jointing materials (see Fig. 7B). In the former case, the width of the gap should be sufficient to allow the sides to be prepared before filling.

The time interval between casting of main parts of structure and the gap in member shall be such that maximum shrinkage in concrete is allowed to take place, as well the temperature of the main concrete structure is as less as possible, to take advantage of maximum strain already taken place, and remaining strain will be smaller, after the gap is cast, thus cracking of structure is controlled.

Where measures are taken for example, by the inclusion of suitable jointing materials to maintain the water tightness of the concrete subsequent to the filling of joint, these type of joints may be regarded as being equivalent to a contraction (partial or complete) as defined earlier above.

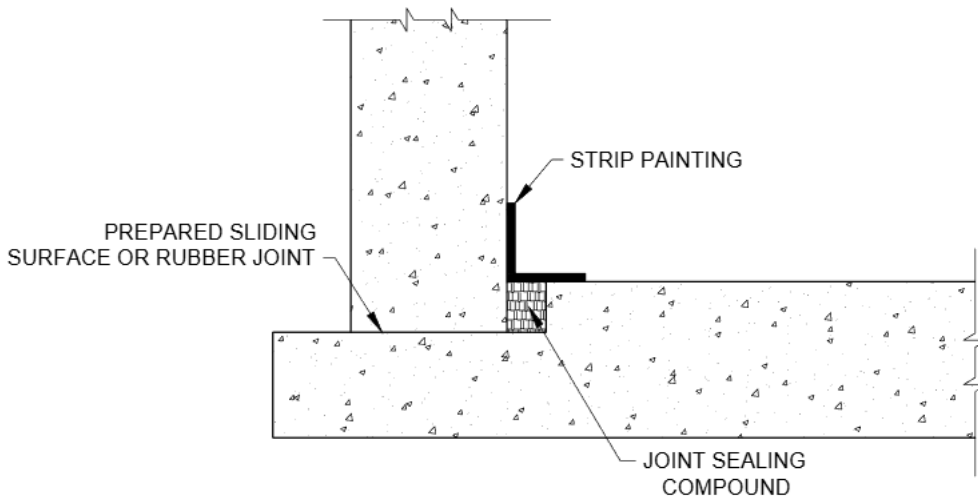

FIG. 5 TYPICAL SLIDING JOINT

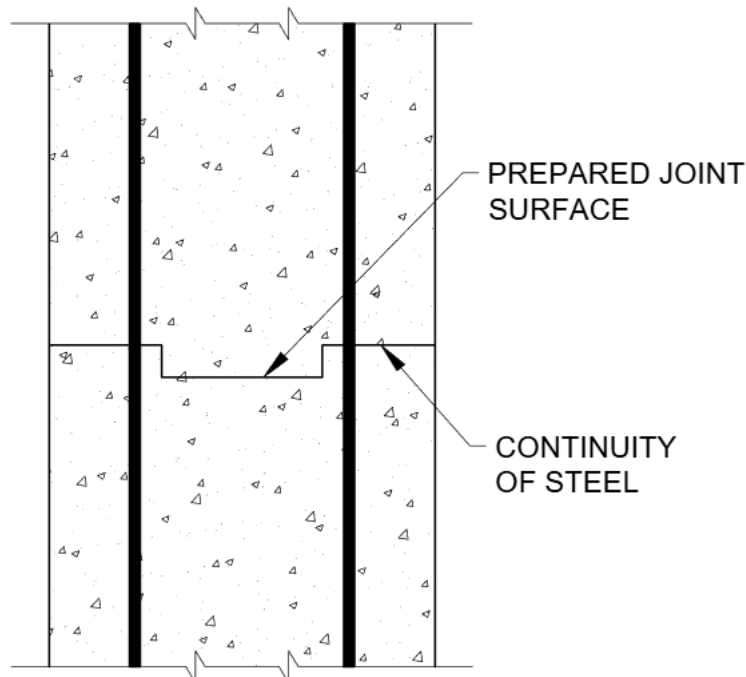

FIG. 6 TYPICAL CONSTRUCTION JOINT

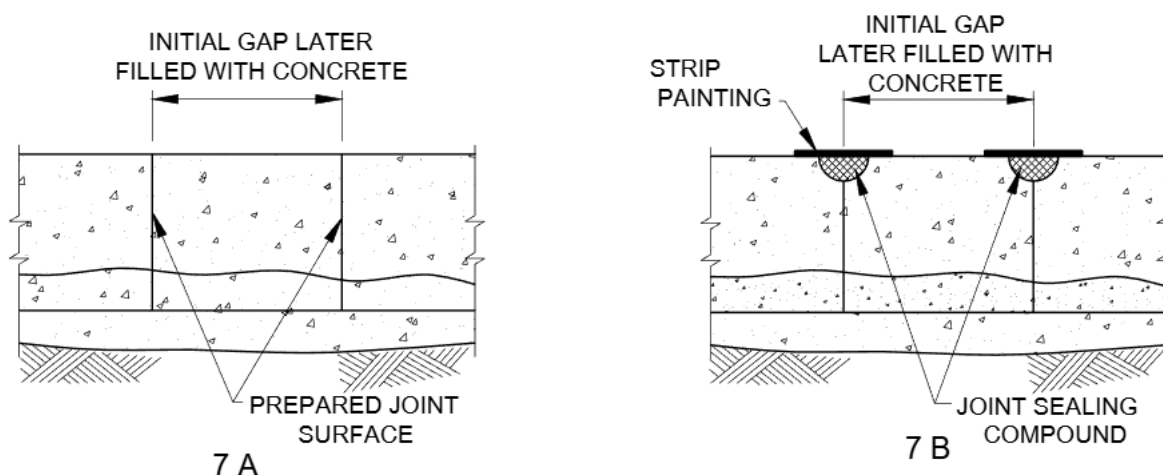

FIG. 7 TYPICAL TEMPORARY OPEN JOINTS

11.3 Design and Detailing of Joints

Design of a movement joint should aim at obtaining the following desirable properties for its efficient functioning:

- a) The joint should accommodate repeated movement of the structure without loss of water tightness.
- b) The design should provide for exclusion of grit and debris to prevent the closing of the joint.
- c) The material used in the construction of movement joints should have the following properties:
 - 1) It should not suffer permanent distortion or extrusion and should not be displaced by fluid pressure.
 - 2) It should not slump unduly in hot weather or become brittle in cold weather.
 - 3) It should be insoluble and durable and should not be affected by exposure to light or by evaporation of solvent or plasticizers.
 - 4) In special cases, the materials should be non-toxic, taintless or resistant to chemical and biological action as may be specified.

Congestion of reinforcement should be avoided during detailing. Various methods, such as choosing the diameter and grade of steel carefully and bundling of reinforcement, if required, should be adopted.

11.4 Spacing of Movement Joints

The provision of movement joints and their spacing are dependent on the design philosophy adopted, that is, whether to allow for or restrain shrinkage and thermal contraction in walls and slabs. At one extreme, the designer may exercise control by providing a substantial amount of reinforcement in the form of small diameter bars at close spacing with no movement joints. On the other extreme, the designer may provide closely spaced movement joints in conjunction with a

moderate proportion of reinforcement. Between these two extremes, control may be exercised by varying the reinforcement and joint spacing, an increase in spacing being compensated for by an increase in the proportion of reinforcement required.

To allow the movement to take place in a movement joint, the top of sub-base shall be in-plane, flat and smooth. Flatness & smoothness of the surface should be specified and controlled. Even if the smoothness is within specified limit, the very small roughness of sub-base will cause the concrete above to set and offer some friction. Hence a separation (or bond breaking) layer should be put in between to allow in-plane shear deformation between bottom and top layers. Normally, thick polyethylene sheet conforming to IS 2508 is specified with smooth top sub-base. It should be noted that local thickening of structural concrete should not create projections below the interface allowing movements. Such projection, if provided, will lock the free movement and induce unwanted cracks.

The three main options for the designer are summarized in Table 2 as follows:

- a) *In Option 1 (Design for full restraint)* — No contraction joints are provided within the area designed for continuity; and crack widths and spacing are controlled by reinforcement. Construction joints become part of the crack pattern and have similar crack widths.
- b) *In Option 2 (Design for partial restraint)* — Cracking is controlled by the reinforcement, but the joint spacing is such that some of the daily and seasonal movements in the mature slab or structural member are accommodated at the joints, so reducing the amount of movement to be accommodated at the cracks between the joints.
- c) *In Option 3 (Design for freedom of movement)* — Cracking is controlled by

proximity of the joints, with a moderate amount of reinforcement provided, sufficient to transmit movement at any cracked section to the adjacent movement joints. Significant cracking between the adjacent movement joints should not occur.

The options given in Table 2 are considered in terms of horizontal movement, but vertical movement in walls should also be considered. Two cases are as follows:

- 1) It is possible for horizontal cracks to occur at any free-standing vertical end because of the change in horizontal restraint with respect to height. For bays of any height the vertical strain arising from this warping effect may be taken as approximately half the horizontal strain, and the vertical steel ratio should not be less than the critical ratio, ρ_{crit} .
- 2) The vertical restraint exerted on a newly cast bay at a vertical construction joint may be assumed to develop at the depth of 2.4 m from the free top surface. Thus design for freedom of movement (Option 3) may be used for vertical reinforcement in the top 2.4 m of a lift of wall. The design for partial restraint (Option 2) is appropriate for vertical steel below this depth.

The choice of design imposes a discipline on construction. It is desirable to achieve minimum restraint to early thermal contraction of the immature concrete in walls and slabs even though the finished structure may be designed for full continuity. Cracks arising from thermal contraction in a roof supported on columns may be minimized or even prevented if the roof slab is not tied rigidly to the walls during constructions.

11.5 Making of Joints

Joints shall generally be made according to the broad principles discussed in 11.5.1 to 11.5.3.

11.5.1 Construction Joints

11.5.1.1 Construction joints shall be located at accessible locations to permit working and good workmanship at the interface like cleaning and roughening.

Time lag between the two concrete phases is an important parameter for the behaviour of the joint. The time lag is to be measured from the instance of mixing of concrete of first phase to the instance when second phase concrete is compacted against the first phase concrete already laid. When the time lag is less than that of 80 percent of the initial setting time of first phase concrete and also

Table 2 Design Option for Control of Thermal Contraction and Restrained Shrinkage
(Clause 11.4)

Sl No.	Option	Construction Type and Method of Control	Movement Joint Spacing	Steel Ratio (see Note 2)	Comments
(1)	(2)	(3)	(4)	(5)	(6)
i)	1	Continuous: For full restraint	No joints, but expansion joints at wide spacing ($\neq 40$ m) may be desirable in walls and roofs that are not protected from solar heat gain or where the retained liquid is subjected to a substantial temperature range.	More than ρ_{crit}	Use small size bars at close spacing to avoid high steel ratios well in excess of ρ_{crit}
ii)	2	Semi-continuous: For partial restraint	a) Complete joints: ≤ 15 m b) Alternate partial and complete joints (by interpolation): ≤ 11.25 m c) Partial joints: ≤ 7.5 m	More than ρ_{crit}	Use small size bars but less steel than in Option 1
iii)	3	Close movement joint spacing: For freedom of movement	a) Complete joints (in metres): $\leq 4.8 + \frac{w}{\epsilon}$ b) Alternate partial and complete joints (in metres): $\leq 0.5 s_{max} + 2.4 + \frac{w}{\epsilon}$ c) Partial joints: $\leq s_{max} + \frac{w}{\epsilon}$	$2/3 \rho_{crit}$	–

NOTES

1 References should be made to Annex A and Annex B of IS 3370 (Part 2) for the description of the symbols used in this table and for calculating ρ_{crit} , s_{max} and ϵ .

2 In options 1 and 2, the steel ratio will generally exceed ρ_{crit} to restrict the crack widths to acceptable values. In option 3, the steel ratio of $2/3 \rho_{crit}$ will be adequate.

while second phase concrete is still plastic, it results in a monolithic concrete across the joint, else the construction joint is assumed to form.

The time lag may be in minutes, hours or in days. As the time lag increases, temperature and shrinkage effects set in as the two concrete are in different phases of setting. Hence due to differential movement (strains), slip develops and reduces the bond between the two concrete. Formation and development of cracks takes place at lower values of strain. Hence, the design and specifications at the joint depends upon the probable time lag at the joint.

Concrete in both phases (earlier and later) should be fully compacted to remove macro pores, and the interface should result in an impermeable joint. In each phase, care is needed to compact the concrete without segregation, simultaneously avoiding loose aggregate and porosity. While ensuring full compaction, there is a possibility that at the joint, top few millimetre concrete (earlier pour) may be over vibrated due to which coarse aggregates may sink and only mortar may remain at top, and this portion of mortar should be removed. Removal of mortar portion may be carried out by applying a surface retarder immediately after concreting the earlier pour. For vertical surfaces, the surface retarder may be applied to the formwork. Alternately, roughening is done by mechanical methods.

Sprayed curing membranes and form-release agents should be thoroughly removed from joint surfaces. As soon as possible after concrete is set, surface laitance, mortar layer, portions of un-compacted concrete if any, loose aggregates or those having cavities around, etc shall be removed. The laitance can be removed by wire brushing or applying a jet of water. If the joint surface is not roughened before the concrete is hardened; in that case, the laitance should be removed by sand blasting or by a scrubber.

At joint interface, concrete surface of the earlier pour should be prepared rough to increase the bond strength and achieve mechanical friction through aggregate interlock, preventing the relative movement (shear slip). Concrete surface at interface should be prepared rough with clean coarse aggregates projecting out from matrix. Joint surface should expose larger aggregates, leaving solid and rough concrete surface, by removing some mortar from it. Mean roughness (measured as half the average height of valley to peak of the surface undulations) should be one-sixth to one-fourth of the maximum size of the aggregate that is, 3 to 5 mm for 20 mm maximum size of aggregate.

Roughening can be done by wire brushing while concrete is still green without dislodging or disturbing the coarse aggregates. At higher ages, this may be done by sand blasting, shot blasting, hydro blasting, milling tool, bush hammer, chiselling, or any other established

method. Use of excessive energy, causing damage by dislodging or fracturing aggregates shall be avoided. In the case of construction joints at locations where the previous pour has been cast against shuttering, the recommended method of obtaining a rough surface for the previously poured concrete is to expose the aggregate with a high pressure water jet or any other appropriate means.

From the surface of first phase concrete which is already roughened, all loose material shall be removed, and washed clean by jet of water. The cleaned joint surface should be dampened for at least 6 h prior to placing new concrete.

Before placing fresh concrete, the old concrete should be saturated, without surface water at the joint (that is, surface dry). New concrete should be fully compacted against old, without voids and segregation. All horizontal construction joints where H/t ratio is more than 15 and all vertical construction joints should be properly grouted. For grouting, cement may be mixed with finer fly ash or GGBS. As H/t ratio increases above 30, the importance of workmanship increases to get a joint with sufficiently low permeability.

Provision of groove or shear key at construction joint is not necessary if the shear stress is less than the shear friction (say half the shear strength of concrete). Joint should be designed for the shear strength. Where high shear resistance is required, shear keys shall be provided.

Water-bars may be provided if thickness of the tank wall exceeds 300 mm.

11.5.1.2 Height of fall of concrete on hard surface and segregation

At a horizontal joint, placing of the concrete of second phase involves fall of concrete. While, the fresh concrete falls on the hard surface, the particles of coarse aggregate rebound and collect near the surface of form work, thus introducing segregation. From the concrete of first fall, some paste adheres to shuttering surface and reinforcement during falling; thus the paste demand is little higher in initial quantity of concrete pour. Higher the free fall of concrete, more will be the rebound and segregation of the aggregates. After a padding layer of concrete is deposited, aggregate from the falling concrete gets embedded in the padding concrete and segregation is not seen at the formed surface of concrete. Hence, at horizontal construction joint, honeycomb is seen only for few cm height. This height of likely honeycomb depends up on the height of free fall of concrete. To avoid this problem, concrete for initial few cm height should be placed by chute/pipe without any freefall. Any other suitable method(s) may also be adopted to prevent freefall/segregation of concrete.

11.5.2 *Movement Joints*

These require the incorporation of special materials in order to maintain liquid tightness whilst accommodating relative movement between the sides of the joint (*see 11.5*).

Movement joints, particularly those in floor and roof, also require protection against the entry of debris which may interfere with the closing of the joints.

11.5.2.1 *Contraction joints*

The joints face of the first-cast concrete should be finished against a stopping-off board, or vertical end shutter which, in case of a partial contraction joint, should be notched to pass the reinforcement.

Steps should be taken to prevent any appreciable adhesion between the new and the old concrete.

The joint should be suitably treated with water-stops and joint sealants so as to maintain liquid tightness during movement of the joint and prevention of debris entering the joints (*see Fig. 8 and 12*).

11.5.2.2 *Expansion joints*

These require the provision of an initial gap between the concrete faces on the two sides of the joints and this can be conveniently done by the use of materials discussed in 12. The initial width of this gap should be specified by the engineer and should be sufficient to accommodate freely the maximum expansion of the structure. In determining jointing materials due consideration should be given to the requirements of the initial width. These will normally require the maintenance of a certain minimum width of gap during maximum expansion of the structure. The joint should be suitably treated so as to maintain liquid tightness during movement of the joint (*see Fig. 9*).

11.5.2.3 *Sliding joints*

The two concrete faces of a sliding joint should be plane and smooth.

Care should be taken by the use of a rigid screening board or other suitable means to make the top of the lower concrete as flat and smooth as possible. This surface may be improved by finishing with a steel float and rubbing down with carborundum.

Bond between the concrete of the two components should be prevented by painting, or by inserting building paper, or other suitable material.

The joint should be suitably treated so as to maintain liquid tightness during movement of the joint.

11.5.3 *Temporary Open Joints*

The concrete on both sides of the joints should be finished against stopping off boards.

In order to minimize the extent of subsequent movements due to shrinkage the joint should be left open until shortly before the reservoir is put into service and then filled in with concrete or mortar of specified properties. Where possible, the joint should be filled when the temperature is low.

Immediately before filling the gap, the joint faces should be thoroughly cleaned and prepared in the same way as for construction joints (*see 11.5.1*).

Where it is intended to treat this type of joint as equivalent to a contraction joint for the purpose of this standard, the joint should be suitably sealed so as to maintain liquid tightness during subsequent movement of the joint.

NOTE — Figures 1 to 9 given in this standard are only diagrammatic, and are intended merely to illustrate the definitions and principles given in the standard and may not be treated as preferred designs.

11.5.4 *Joints in Ground Slabs*

The floor of a structure may be designed to permit thermal contraction and shrinkage by minimizing restraints to movement or fully restrained against shrinkage and thermal contraction and cast directly onto the blinding concrete.

A separating layer of polyethylene conforming to IS 2508 should be provided between the floor slab and the blinding concrete. Panels may be cast in single bays or in larger areas with induced joints. Frequently, in large structures, the floor is designed as a series of continuous strips with transverse induced complete contraction joints provided to ensure that cracking occurs in predetermined positions. Longitudinal joints between the strips should form complete contraction joints.

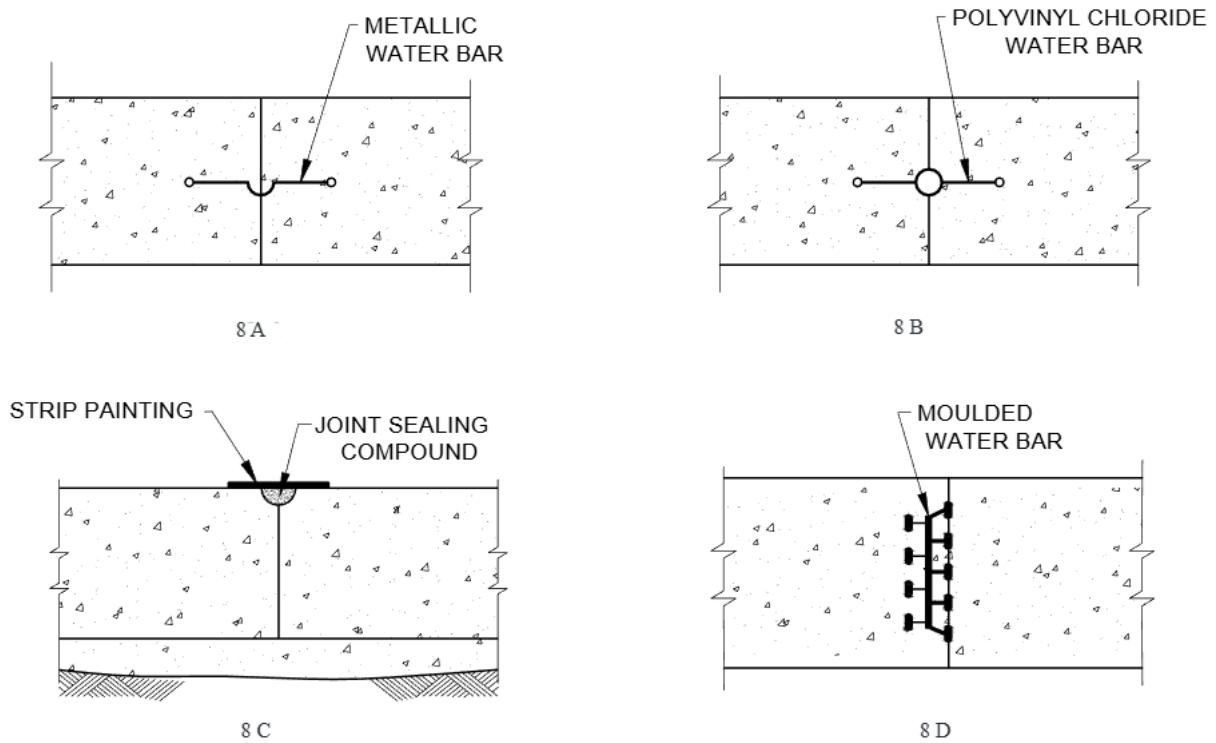

FIG. 8 TYPICAL DETAILS SHOWING USE OF JOINTING MATERIALS IN MOVEMENT JOINTS (CONTRACTION TYPE)

11.5.5 Joints in Walls

Walls may be designed as fully restrained against thermal contraction and shrinkage, or the restraints may be reduced by providing movement joints in accordance with Table 2. Where the wall is designed to be monolithic with the base slab, a kicker of at least 75 mm height may be cast at the same time as, and integrally with, the slab to enable the next lift of formwork to fit tightly and avoid leakage of cement grout from the newly deposited concrete. The joint in this position will be a construction joint, and although it is recommended that wall panels are cast in one lift, any necessary extra horizontal joints will be construction joints.

In walls to circular structures, one of the predominant forces from the liquid pressure is horizontal hoop tension. For structural design purposes, the horizontal reinforcement should be completely continuous at vertical joints. A central water-bar may be used together with sealing compounds on both faces.

11.5.6 Joints in Roofs

Where roof slabs are designed as flat slabs, all interior joints should be construction joints so that the slab is structurally monolithic, considering early thermal effects and subsequent temperature effects. Roofs, even those covered by soil, may be subjected to a larger thermal change than the walls and floor. However, the

subsequent temperature effects may be disregarded, if the roof is not connected monolithically to the wall. Where roofs and walls are monolithic, movement joints in roofs should correspond with those in the walls to avoid the possibility of sympathetic cracking. If, however, provision is made by means of a sliding joint for movement between the roof and walls, correspondence of the joints is less important.

12 JOINTING MATERIALS

The joints described in 11.2 require the use of combinations of jointing materials, which may be classified as:

- a) Joint fillers,
- b) Water-bars, and
- c) Joint sealants (including primers, where required).

These materials are inaccessible once the liquid retaining structure is commissioned and hence, the same should be considered during the design. Satisfactory adhesion between joint sealants and the concrete surfaces between which they are to provide a liquid tight seal shall be ensured. Notwithstanding the presence of joint sealants, water-bars should always be provided in movement joints.

When proprietary materials or products are used, the recommendations of the manufacturer should be followed.

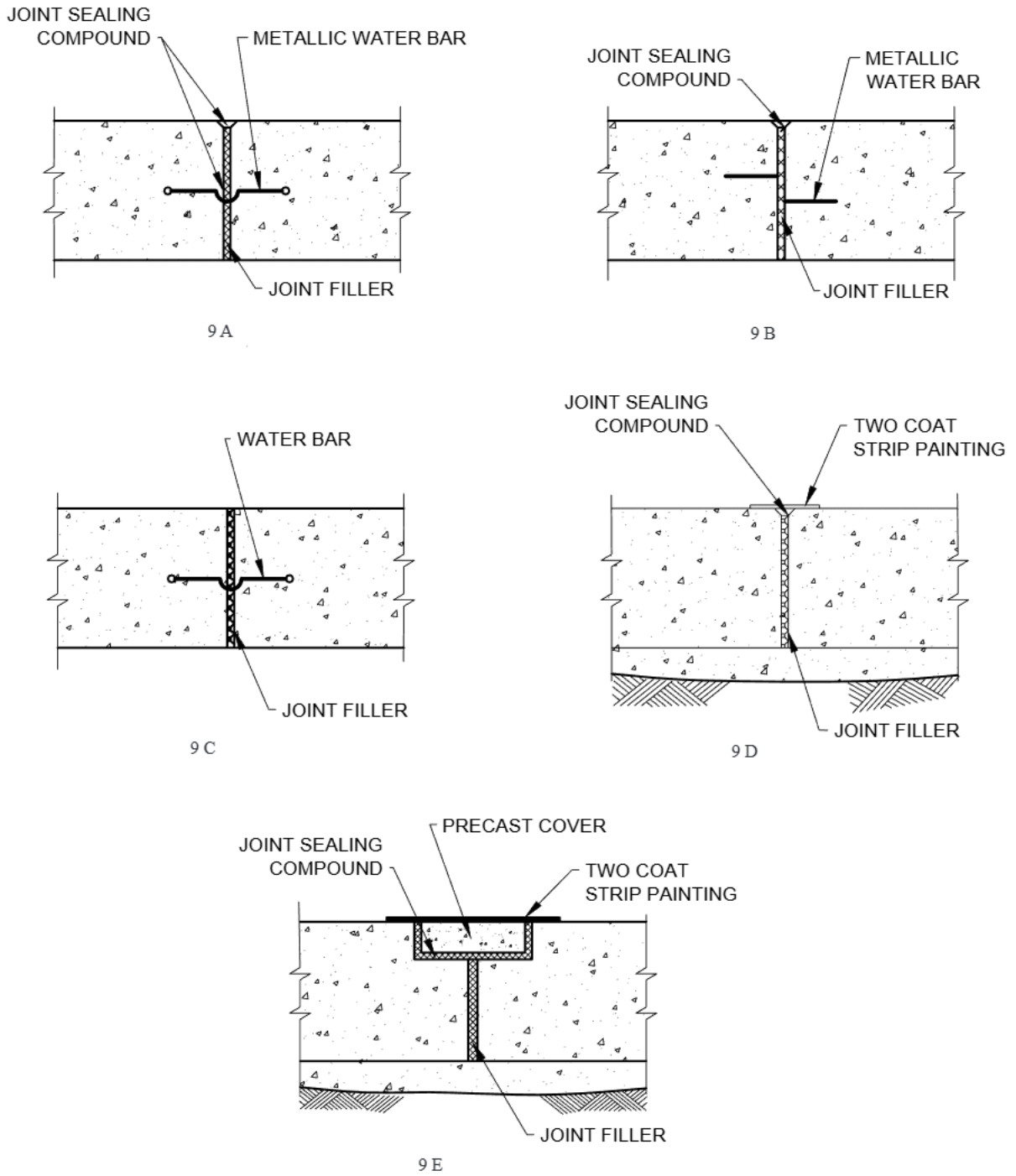

FIG. 9 TYPICAL DETAILS SHOWING USE OF JOINTING MATERIALS IN MOVEMENT JOINTS (EXPANSION TYPE)

Jointing materials should be capable of accommodating repeated movement without permanent distortion or extrusion, and they should not be displaced by liquid pressure. The jointing materials should not have any detrimental effect on concrete and steel.

12.1 Joint Fillers

Joint fillers are usually compressible sheet or strip materials used as spacers. Only non-rotting and non-absorbent materials should be used as joint fillers.

They are used in expansion joints and are fixed to the face of the first placed concrete and against which the second placed concrete is cast. They provide the initial separation between the faces of the concrete and compress under the predetermined expansion from each face of the concrete. It is important that the joint filler accommodates the compression without transferring appreciable load across the expansion joint and recovers so that the joint remains filled when the concrete faces subsequently move apart.

Joint fillers, may themselves function as liquid-tight expansion joints. These may be used as support for an effective joint sealant in floor and roof joints. But they may only be relied upon as spacers to provide the gap in an expansion joint, the gap being bridged by a water-bar (*see* Fig. 9).

12.2 Water-bars

Water-bars are preformed strips of impermeable material which are wholly or partially embedded in the concrete during construction so as to span across the joint to provide a permanent liquid tight seal during the whole range of joint movement.

For example, water-bars may be strips with a central longitudinal corrugation (*see* Fig. 8A and Fig. 9A), Z shaped strips (*see* Fig. 9B) and a central longitudinal hollow tube (*see* Fig. 8B and Fig. 9C) with thin walls with stiff wings of 150 mm - 250 mm width. The material used for the water-bars are metal sheet, natural or synthetic rubbers and plastic, such as polyvinyl chloride (PVC). Galvanized iron sheets may also be used with the specific permission of the engineer-in-charge provided the liquids stored or the atmosphere around the liquid retaining structure is not excessively corrosive, for example, sewage. While selecting the materials for water base, the possible corrosion aspects, chemical resistance, joint movement capacity, and design temperature range should be kept in mind.

With all water-bars, proper compaction of the concrete placed around the water-bars shall be ensured. The bar should have such shape and width that the water path through the concrete round the bar should not be unduly short.

The holes, sometimes provided on the wings of water-bars to tie it in position or to increase bond, shorten the water path and may be disadvantageous. The water-bar should either be placed centrally in the thickness of the wall or its distance from either face of the wall should not be less than half the width of the bar. The specified concrete cover to all reinforcement should be maintained.

The strip water-bars at present available in the newer materials need to be passed through the end shutter of the first-placed concrete. It can be appreciated, however, that the use of newer materials makes possible a variety of shapes or sections. Some of these designs, for example, those with several projections (*see* Fig. 9D), would not need to be passed through the end shutter and by occupying a bigger proportion of the thickness of the joint would also lengthen the shortest alternative water path through the concrete.

The hydrophilic water-bars, which swell in the presence of water to seal the joint, may be placed in the middle of the construction joints providing suitable cover on both sides with the help of a suitable adhesive.

The design of the structure should generally provide for the continuity of the water-bar system across all joints and particularly junctions between floor and wall systems. Surface water-bars should be used only in situations where there is sufficient pressure from the outside to ensure that the water-bar remains in position.

12.3 Joint Sealants

Joint sealants conforming to IS 11433 (Part 1), IS 12118 (Part 1) or IS 1834 or any other suitable material based on asphalt, bitumen, or coal tar pitch with or without fillers, such as limestone or slate dust, asbestos fibre, chopped hemp, rubber or other suitable material.

They are impermeable ductile materials, which are required to provide a liquid-tight seal by adhesion to the concrete throughout the range of joint movements. The sealing performance is obtained by permanent adhesion of the sealant to the concrete each side of the joint only, and most sealants should be applied in conditions of complete dryness and cleanliness. There are joint sealants that are produced for application to surfaces that are not dry. These are usually applied after construction or just before the reservoir is put into service by pouring in the hot or cold state, by trowelling or gunning or as preformed strips ironed into position. These may also be applied during construction, such as by packing round the corrugation of a water-bar. A primer is often used to assist adhesion and some local drying of the concrete surface with the help of a blow lamp is advisable. The length of the shortest water path through the concrete should be extended by suitably painting the surface at the concrete on either side of the joint.

The main difficulties experienced with this class of material are in obtaining permanent adhesion to the concrete during movement of the joint whilst at the same time ensuring that the material does not slump or is not extruded from the joint.

In floor joints, the sealant is usually applied in a chase formed in the surface of the concrete along the line of the joint (*see* Fig. 9A). The actual minimum width will depend on the known characteristics of the material. In the case of an expansion joint, the lower part of the joint is occupied by a joint filler (*see* Fig. 9E). This type of joint is generally quite successful since, retention of the material is assisted by gravity and, in many cases, sealing can be delayed until just before the reservoir is put into service so that the amount of joint opening subsequently to be accommodated is quite small. The chase should not be too narrow or too deep to hinder complete filling and the length of the shortest water path through the concrete on either side of the joint. Here, again a wider joint demands a smaller percentage distortion in the material.

An arrangement incorporating a cover slab, similar to that shown in Fig. 9E, may be advantageous in reducing dependence on the adhesion of the sealant in direct tension.

13 CONSTRUCTION

13.1 Unless otherwise specified in this standard, the provisions of IS 456 and IS 1343 shall apply to the construction of reinforced concrete and pre-stressed concrete liquid retaining structures, respectively.

During construction or initial life, tank shall not be kept empty for a period of more than 3 days and should be filled with water/liquid of minimum 300 mm depth to avoid drying shrinkage cracks in the concrete structure and plaster, if any on inside face of wall. At the end of liquid-tightness test (*see* 14), the tank should be cleaned and disinfected before commissioning for normal use.

A wearing apron (wearing coat) may be provided on a member where abrasion loss can occur at concrete surface such as where liquid falling from a height of more than 6 m or liquid flowing at a speed of more than 2 m/s.

13.2 Joints

Joints shall be constructed in accordance with requirements of 11.

13.3 Construction of Floors

13.3.1 Floors Founded on the Ground

13.3.1.1 Where walls or floors are founded on the ground, a layer of lean concrete not less than 75 mm thick and weaker than M15, as specified in IS 456 shall be used. Where, however injurious soils or aggressive ground water are expected, the concrete should not be

weaker than M20, and if necessary, sulphate resisting cement conforming to IS 12330 or other special cement, as per IS 456 should be used.

13.3.1.2 Following a layer of lean concrete, the floor shall be cast in a single layer. If movement joints are provided as per 9.2.8(b), a separating layer of polyethylene sheet conforming to IS 2508 should be provided in between the floor slab and the layer of lean concrete. The top surface of PCC shall be rendered smooth before laying separating layer. If structure is designed continuous without movement joints as per 9.2.8(a), the lean concrete top may be allowed to be rough, and the concrete floor over it without any separating layer.

13.3.1.3 Minimum thickness of floor slab on ground shall be 160 mm, if having reinforcement on each face. Suspended floor slab shall be minimum 180 mm thick, for span greater than 3.5 m.

13.4 Construction of Walls

13.4.1 The height of any lift should be as large as possible. It is desirable to place the concrete to full height of the member in one go. Thorough compaction by vibration shall be ensured.

13.4.2 All vertical joints should extend the full height of the wall in unbroken alignment.

13.4.3 Wall thickness 200 mm or more is normally recommended. However, minimum thickness of wall may be 160 mm for small tanks of height less than 2 m. In treatment plants, walls of channels/louder may be 125 mm thick if single layer bar mesh is required.

13.5 Surface Finish to Prestressed Concrete Cylindrical Tanks

The circumferential prestressing wires of a cylindrical tank should be covered with a protective coat, which may be pneumatic mortar, having a thickness that will provide a minimum cover of 40 mm over the wires. The protective coat shall have specifications designed to get a long life service expectancy for prestressing wires.

13.6 Formwork

13.6.1 Removal of Formwork

The requirements shall conform to IS 456.

13.6.2 Bolts passing completely through liquid retaining slabs for the purpose of securing and aligning the form work should not be used unless effective precautions are taken to ensure liquid tightness after removal.

13.7 Lining of Tanks

The type of liquid to be stored should be considered in relation to the possibility of corrosion of the steel or attack on the concrete. Provision of an impermeable

protective lining should be considered for resistance to the effects of corrosive liquids. Certain liquids exhibit corrosive characteristics and in such cases it is important to obtain a dense impermeable concrete and with a higher cement content. An increased cover to the steel is also desirable. The use of sulphate resisting Portland cement conforming to IS 12330, Portland pozzolana cement conforming to IS 1489 (Part 1), and Portland slag cement conforming to IS 455 may, in certain cases, be advantageous. Poly-aluminium chloride tanks and alum solution tanks shall be provided with acid resistance coating or lining.

14 TEST OF STRUCTURE

14.1 General

In addition to the structural tests given in IS 456, liquid retaining structures shall also be tested for liquid tightness at full supply level (or design capacity) as per 14.2. Further, the roofs of the liquid retaining structures shall be tested as per 14.3.

14.2 Testing of Structures

The structure should be cleaned and initially filled to the normal maximum level with the specified liquid at a uniform rate of not greater than 2 m in 24 h. When first filled, the liquid level should be maintained by the addition of further liquid for a stabilizing period while absorption and autogenous healing take place. The stabilizing period may be 7 days for maximum design crack width of 0.1 mm or 21 days for 0.2 mm or greater. After the stabilizing period, the level of the liquid surface shall be recorded at 24 h intervals for a test period of 7 days. During this 7 day test period, the total permissible drop in level, after allowing for evaporation and rainfall, should not exceed the maximum of 1/500th of the average water depth of the full tank and 10 mm or another specified value, mutually agreed between the parties to contract.

In case of underground tanks whose top is covered, the total permissible drop in the surface level over a period of 7 days shall not exceed 20 mm.

Notwithstanding the satisfactory completion of the test, any evidence of seepage of the liquid to the outside faces of the liquid retaining walls should be assessed against the requirements of the specification. Any necessary remedial treatment of the concrete, cracks, or joints should, where practicable, be carried out from

the liquid face, if grouts, such as cement based grouts, are used which can't perform in the presence of liquid, or from the outer face, if grouts, such as polyurethane grouts, are used whose efficacy in presence of water/liquid is well established. Where a remedial lining is applied to inhibit leakage at a crack, it should have adequate flexibility and have no adverse reaction with the stored liquid.

14.2.1 If the structure does not satisfy the 7 day test, then it should be retested after the completion of the remedial work. Remedial work may be undertaken in presence of water, if repair materials, such as polyurethane grouts, are used whose efficacy in presence of water is well established. However, if grouts, such as cement based grouts, are used which can't perform in presence of water, remedial treatment shall be carried out only after emptying the tank. The tank should be accordingly refilled and, if necessary, left for a further stabilizing period; a further test of 7 days' duration be undertaken in accordance with 14.2.

14.3 Testing of Roofs

The roofs of liquid retaining structures should be liquid tight and should be tested on completion by flooding the roof with water to a minimum depth of 25 mm for 24 h or longer, if so specified. Where it is impracticable, because of roof slopes or otherwise, to contain a 25 mm depth of water, the roof should have continuous water applied by a hose or sprinkler system to provide a sheet flow of water over the entire area of the roof for not less than 6 h. In either case, the roof should be considered satisfactory if no leaks or wet patches show on the soffit.

14.3.1 If the structure does not satisfy the test given in 14.3, then it should be retested after the completion of the remedial work in accordance with this clause. The roof insulation and covering, if any, should be completed as soon as possible after satisfactory testing.

15 LIGHTNING PROTECTION

The liquid retaining structures shall be protected against lightning in accordance with IS/IEC 62305 (Parts 1 to 3).

16 VENTILATION

The ventilation shall be provided in plan and elevation, as mutually agreed between parties to contract.

ANNEX A

(Clause 2)

LIST OF REFERRED INDIAN STANDARDS

<i>IS No.</i>	<i>Title</i>	<i>IS No.</i>	<i>Title</i>
383 : 2016	Coarse and fine aggregates for concrete — Specification (<i>third revision</i>)	3370 (Part 4) : 2021	Concrete structures for retaining aqueous liquids — Code of practice: Part 4 Design tables (<i>first revision</i>)
455 : 2015	Portland slag cement — Specification (<i>fifth revision</i>)	11433 (Part 1) : 1985	Specification for one part gun-grade polysulphide-based joints sealants: Part 1 General requirements
456 : 2000	Code of practice for plain and reinforced concrete (<i>fourth revision</i>)	11682 : 1985	Criteria for design of RCC staging for overhead water tanks
1343 : 2012	Code of practice for prestressed concrete (<i>second revision</i>)	12118 (Part 1) : 1987	Two-part polysulphide-based sealants — Specification: Part 1 General requirements
1489 (Part 1) : 2015	Portland pozzolana cement— Specification: Part 1 Fly ash based (<i>fourth revision</i>)	12330 : 1988	Specification for sulphate resisting portland cement
1834 : 1984	Hot applied sealing compounds for joints in concrete — Specification (<i>first revision</i>)	13620 : 1993	Fusion bonded epoxy coated reinforcing bars — Specification
1893 (Part 1) : 2016	Criteria for earthquake resistant design of structures: Part 1 General provisions and buildings (<i>sixth revision</i>)	16651 : 2017	High strength deformed stainless steel bars and wires for concrete reinforcement— Specification
1893 (Part 2) : 2014	Criteria for earthquake resistant design of structures: Part 2 Liquid retaining tanks (<i>fifth revision</i>)	16714 : 2018	Ground granulated blast furnace slag for use in cement, mortar and concrete — Specification
2508 : 2016	Polyethylene films and sheets — Specification (<i>third revision</i>)	IS/IEC 62305 (Part 1) : 2010	Protection against lightning: Part 1 General principles
3370 (Part 2) : 2021	Concrete structures for retaining aqueous liquids — Code of practice: Part 2 Plain and reinforced concrete (<i>second revision</i>)	IS/IEC 62305 (Part 2) : 2010	Protection against lightning: Part 2 Risk management
3370 (Part 3) : 2021	Concrete structures for retaining aqueous liquids — Code of practice: Part 3 Prestressed concrete (<i>first revision</i>)	IS/IEC 62305 (Part 3) : 2010	Protection against lightning: Part 3 Physical damage to structures and life hazard

ANNEX B

(Foreword)

COMMITTEE COMPOSITION

Cement and Concrete Sectional Committee, CED 02

<i>Organization</i>	<i>Representative(s)</i>
In Personal Capacity (<i>Grace Villa, Kadamankulam P.O., Thiruvalla 689 583</i>)	SHRI JOSE KURIAN (Chairman)
ACC Ltd, Mumbai	SHRI RAJESH J. MODI DR MANISH V. KARANDIKAR (<i>Alternate</i>)
Ambuja Cements Limited, Ahmedabad	SHRI UMESH P. SONI SHRI SUKURU RAMARAO (<i>Alternate</i>)
Atomic Energy Regulatory Board, Mumbai	SHRI L. R. BISHNOI SHRI SOURAV ACHARYA (<i>Alternate</i>)
Builders' Association of India, Mumbai	SHRI SUSHANTA KUMAR BASU SHRI D. R. SEKOR (<i>Alternate</i>)
Building Materials & Technology Promotion Council, New Delhi	SHRI C. N. JHA
Cement Manufacturers' Association, Noida	DR V. RAMACHANDRA Ms SHASHWATI GHOSH
Central Public Works Department, New Delhi	SHRI D. K. GARG SHRI NAVEEN KUMAR BANSAL (<i>Alternate</i>)
Central Soil and Materials Research Station, New Delhi	DIRECTOR SHRI U. S. VIDYARTHI (<i>Alternate</i>)
Central Water Commission, New Delhi	DIRECTOR (CMDD) (N&W) DEPUTY DIRECTOR (CMDD) (NW&S) (<i>Alternate</i>)
Conmat Technolgies Pvt Ltd, Kolkata	DR A. K. CHATTERJEE DR SUBRATO CHOWDHURY (<i>Alternate</i>)
Construction Chemical Manufacturers' Association, Mumbai	SHRI SAMIR SURLAKER SHRI NILOTPOL KAR (<i>Alternate</i>)
CSIR – Central Building Research Institute, Roorkee	SHRI S. K. SINGH SHRI SUBHASH GURRAM (<i>Alternate</i>)
CSIR – Central Road Research Institute, New Delhi	DR RAKESH KUMAR DR V. V. L. KANTA RAO (<i>Alternate</i>)
CSIR – Structural Engineering Research Centre, Chennai	DR K. RAMANJANEYULU DR P. SRINIVASAN (<i>Alternate</i>)
Delhi Development Authority, New Delhi	SHRI LAXMAN SINGH SHRI VIJAY SHANKAR (<i>Alternate</i>)
Department of Science and Technology, Ministry of Science and Technology, New Delhi	SHRI S. S. KOHLI
Engineers India Limited, New Delhi	SHRI RAJANJI SRIVASTAVA SHRI ANURAG SINHA (<i>Alternate</i>)
Gammon India Limited, Mumbai	SHRI SHRIRAM B. KULKARNI SHRI RAHUL BIRADAR (<i>Alternate</i>)
Hindustan Construction Company Limited, Mumbai	SHRI SATISH KUMAR SHARMA SHRI MUKESH VALECHA (<i>Alternate</i>)
Housing and Urban Development Corporation Limited, New Delhi	REPRESENTATIVE

<i>Organization</i>	<i>Representative(s)</i>
Indian Association of Structural Engineers, New Delhi	SHRI MAHESH TANDON SHRI GANESH JUNEJA (<i>Alternate</i>)
Indian Concrete Institute, Chennai	SHRI VIVEK NAIK SECRETARY GENERAL (<i>Alternate</i>)
Indian Institute of Technology Delhi, New Delhi	DR SHASHANK BISHNOI DR DIPTI RANJAN SAHOO (<i>Alternate</i>)
Indian Institute of Technology Madras, Chennai	DR DEVDAS MENON DR MANU SANTHANAM (<i>Alternate</i>)
Indian Institute of Technology Roorkee, Roorkee	DR V. K. GUPTA DR BHUPINDER SINGH (<i>Alternate</i>)
Indian Roads Congress, New Delhi	SHRI S. K. NIRMAL SHRI R. V. PATIL (<i>Alternate</i>)
Military Engineer Services, Engineer-in-Chief's Branch, Army HQ, New Delhi	MAJ GEN S. K. SRIVASTAV SHRI MAN SINGH (<i>Alternate</i>)
Ministry of Road Transport and Highways, New Delhi	SHRI Y. BALAKRISHNA SHRI SANJEEV KUMAR (<i>Alternate</i>)
National Council for Cement and Building Materials, Ballabgarh	SHRI V. V. ARORA DR S. K. CHATURVEDI (<i>Alternate</i>)
National Test House, Kolkata	SHRI D. V. S. PRASAD DR SOMIT NEOGI (<i>Alternate</i>)
Nuclear Power Corporation of India Ltd, Mumbai	SHRI ARVIND SHRIVASTAVA SHRI RAGHUPATI ROY (<i>Alternate</i>)
Nuvoco Vistas Corporation Limited, Mumbai	SHRI PRANAV DESAI SHRI RAVINDRA KHAMPARIA (<i>Alternate</i>)
Public Works Department, Govt of Tamil Nadu, Chennai	SUPERINTENDING ENGINEER EXECUTIVE ENGINEER (<i>Alternate</i>)
The India Cements Limited, Chennai	REPRESENTATIVE
The Indian Hume Pipe Company Limited, Mumbai	SHRI P. R. BHAT SHRI S. J. SHAH (<i>Alternate</i>)
The Institution of Engineers (India), Kolkata	DR H. C. VISVESVARAYA SHRI S. H. JAIN (<i>Alternate</i>)
The Ramco Cements Limited, Chennai	SHRI BALAJI K. MOORTHY SHRI ANIL KUMAR PILLAI (<i>Alternate</i>)
Ultra Tech Cement Ltd, Mumbai	SHRI SURYA VALLURI DR M. R. KALGAL (<i>Alternate</i>)
Voluntary Organization in Interest of Consumer Education, New Delhi	SHRI M. A. U. KHAN SHRI B. MUKHOPADHYAY (<i>Alternate</i>)
In personal capacity [B-803, Oberoi Exquisite, Oberoi Garden City, Goregaon (East), Mumbai]	SHRI A. K. JAIN
In personal capacity (36, Old Sneh Nagar, Wardha Road, Nagpur)	SHRI L. K. JAIN

<i>Organization</i>	<i>Representative(s)</i>
In personal capacity (<i>EA-92, Maya Enclave, Hari Nagar, New Delhi</i>)	SHRI R. C. WASON
BIS Directorate General	SHRI SANJAY PANT, SCIENTIST 'F' AND HEAD (CIVIL ENGINEERING) [REPRESENTING DIRECTOR GENERAL (<i>Ex-officio</i>)]

Member Secretary
SHRI S. ARUN KUMAR
SCIENTIST 'E' (CIVIL ENGINEERING), BIS
and
SHRI MILIND GUPTA
SCIENTIST 'C' (CIVIL ENGINEERING), BIS

Concrete Subcommittee, CED 2:2

<i>Organization</i>	<i>Representative(s)</i>
In personal capacity (<i>Grace Villa, Kadamankulam P.O., Thiruvalla 689 583</i>)	SHRI JOSE KURIAN (<i>Convener</i>)
ACC Limited, Mumbai	SHRI PRAHLAD MUJUMDAR SHRI ANIL KULKARNI (<i>Alternate</i>)
Ambuja Cement Limited, Ahmedabad	SHRI UMESH P. SONI SHRI SUKURU RAMARAO (<i>Alternate</i>)
AFCONS Infrastructure Limited, Mumbai	SHRI MANISH MOKAL
Association of Consulting Civil Engineers (India), Bengaluru	SHRI AVINASH D. SHIRODE SHRI K. K. MEGHASHYAM (<i>Alternate</i>)
Atomic Energy Regulatory Board, Mumbai	SHRI L. R. BISHNOI SHRI SOURAV ACHARYA (<i>Alternate</i>)
Building Materials and Technology Promotion Council, New Delhi	SHRI PANKAJ GUPTA
Bureau of Design for Hydrel and Irrigation Project, Bhopal	SHRI S. K. KHARE SHRI BHAGWATI PRASAD GUPTA (<i>Alternate</i>)
Bureau Veritas India Ltd, Mumbai	REPRESENTATIVE
Central Public Works Department, New Delhi	SHRI D. K. GARG SHRI RAJESH KHARE (<i>Alternate</i>)
Central Soil and Materials Research Station, New Delhi	SHRI RAJEEV KUMAR SHRI RAJ KUMAR (<i>Alternate</i>)
Creative Design Consultants & Engineers Pvt Ltd, Ghaizabad	SHRI AMAN DEEP SHRI MANIK CHATTERJEE (<i>Alternate</i>)
CSIR – Central Building Research Institute, Roorkee	DR RAJESH DEOLIA SHRI H. C. ARORA (<i>Alternate</i>)
CSIR – Central Road Research Institute, New Delhi	SHRI J. B. SENGUPTA SHRI SATISH PANDEY (<i>Alternate</i>)
CSIR – Structural Engineering Research Centre, Chennai	DR B. H. BHARATHKUMAR DR P. SRINIVASAN (<i>Alternate</i>)
Department of Science and Technology Ministry of Science and Technology, New Delhi	SHRI S. S. KOHLI
Elkem South Asia Pvt Ltd, Navi Mumbai	SHRI BRAJESH MALVIYA SHRI SURENDRA SHARMA (<i>Alternate</i>)
Engineers India Limited, New Delhi	SHRI RAJANI SRIVASTAVA SHRI ANURAG SINHA (<i>Alternate</i>)

<i>Organization</i>	<i>Representative(s)</i>
Gammon India Limited, Mumbai	SHRI SUDEESH RAJENDRAN
Hindustan Construction Company Ltd, Mumbai	SHRI SATISH KUMAR SHARMA SHRI KHATARBATCHA JIMMETAIN (<i>Alternate</i>)
Indian Concrete Institute, Chennai	SHRI K. C. TAYADE SECRETARY GENERAL (<i>Alternate</i>)
Indian Institute of Technology Delhi, New Delhi	DR B. BHATTACHARJEE DR SHASHANK BISHNOI (<i>Alternate</i>)
Indian Institute of Technology Kanpur, Kanpur	DR SUDHIR MISHRA
Indian Institute of Technology Madras, Chennai	DR MANU SANTHANAM DR RADHAKRISHNA G. PILLAI (<i>Alternate</i>)
Indian Institute of Technology Roorkee, Roorkee	REPRESENTATIVE
Indian Society of Structural Engineers, Mumbai	SHRI UMESH JOSHI SHRI HEMANT VADALKAR (<i>Alternate</i>)
Irrigation and Power Research Institute, Amritsar	CHIEF ENGINEER (RESEARCH) RESEARCH OFFICER (<i>Alternate</i>)
Larsen and Toubro Limited, ECC Division, Chennai	DR B. SIVARAMA SARMA SHRI S. MANOHAR (<i>Alternate</i>)
Military Engineer Services, Engineer-in-Chief's Branch, Integrated HQ of MoD (Army), New Delhi	MAJ GEN S. K. SRIVASTAV SHRI MAN SINGH (<i>Alternate</i>)
Ministry of Road Transport and Highways, New Delhi	SHRI A. P. PATHAK SHRI A. K. PANDEY (<i>Alternate</i>)
NBCC (India) Ltd, New Delhi	SHRI H. S. YADAV SHRI ARUN KUMAR SHARMA (<i>Alternate</i>)
National Council for Cement and Building Materials, Ballabgarh	SHRI V. V. ARORA SHRI P. N. OJHA (<i>Alternate</i>)
National Institute of Technology Warangal, Warangal	DR C. B. KAMESWARA RAO DR D. RAMA SESHU (<i>Alternate</i>)
Nuclear Power Corporation of India Limited, Mumbai	SHRI ARVIND SHRIVASTAVA SHRI N. M. RAO (<i>Alternate</i>)
Pidilite Industries Limited, Mumbai	DR SUGUNA NAIK
Ready Mixed Concrete Manufacturers' Association, Mumbai	SHRI VIJAYKUMAR R. KULKARNI SHRI SRIRANG SONDUR (<i>Alternate</i>)
Research, Design & Standards Organisation (Ministry of Railways), Lucknow	JT DIRECTOR STDRS (B&S)/CB-I JT DIRECTOR STDRS (B&S)/CB-II (<i>Alternate</i>)
RDC Concrete (India) Pvt Ltd, Thane	SHRI ANIL BANCHHOR SHRI SIMRANJIT SINGH (<i>Alternate</i>)
Shapoorji Pallonji and Company Private Limited, Mumbai	SHRI GIRISH BONDE SHRI D. N. VISHWANATH (<i>Alternate</i>)
Tandon Consultants Pvt Limited, New Delhi	SHRI MAHESH TANDON SHRI VINAY GUPTA (<i>Alternate</i>)
Tata Consulting Engineers Limited, Mumbai	SHRI S. N. DIWAKAR SHRI MANOS KUMAR DE (<i>Alternate</i>)
Ultra Tech Cement Ltd, Mumbai	DR V. RAMACHANDRA DR A. K. SINGH (<i>Alternate</i>)
Water Resource Department, Govt. of Madhya Pradesh, Mumbai	SHRI S. K. KHARE SHRI B. P. GUPTA (<i>Alternate</i>)
In personal capacity (452 Sector 14, Sonipat, Haryana)	SHRI R. K. JAIN
In personal capacity (36, Old Sneh Nagar, Wardha Road, Nagpur)	SHRI L. K. JAIN

<i>Organization</i>	<i>Representative(s)</i>
In personal capacity [B-803, Oberoi Exquisite, Oberoi Garden City, Goregaon (East), Mumbai]	SHRI A. K. JAIN
In personal capacity (EA-92, Maya Enclave, Hari Nagar, New Delhi)	SHRI R. C. WASON
In personal capacity (MI F1 VGN Minerva Apartments, Guruswamy Road, Nolambur, Chennai)	DR C. RAJKUMAR

Panel for Review/Revision of IS 3370, CED 2:2/P1

<i>Organization</i>	<i>Representative(s)</i>
In personal capacity (36, Old Sneh Nagar, Wardha Road, Nagpur)	SHRI L. K. JAIN (Convener)
Creative Design Consultants & Engineers Pvt Ltd, Ghaziabad	SHRI AMAN DEEP GARG SHRI MANIK CHATTERJEE (<i>Alternate</i>)
CSIR – Central Road Research Institute, New Delhi	DIRECTOR
CSIR – Structural Engineering Research Centre, Chennai	DR B. H. BHARATHKUMAR DR P. SRINIVASAN (<i>Alternate</i>)
Gammon Engineers & Contractors Pvt Ltd, Mumbai	SHRI S. W. DESHPANDE SHRI MUKUND C. BUTALA (<i>Alternate</i>)
Government College of Engineering, Pune	DR NAMDEO A. HEDAOO
Hindustan Construction Company Ltd, Mumbai	SHRI SATISH KUMAR SHARMA SHRI MUKESH VALECHA (<i>Alternate</i>)
Indian Concrete Institute, Chennai	REPRESENTATIVE
Indian Institute of Technology Delhi, New Delhi	DR DIPTI RANJAN SAHOO DR SHASHANK BISHNOI (<i>Alternate</i>)
Indian Institute of Technology Roorkee, Roorkee	DR ASHOK K. JAIN
Military Engineer Services, Engineer-in-Chief's Branch, Integrated HQ of MoD (Army), New Delhi	SHRI J. B. SHARMA SHRI YOGESH K. SINGHAL (<i>Alternate</i>)
National Council for Cement and Building Materials, Ballabgarh	SHRI V. V. ARORA SHRI T. V. G. REDDY (<i>Alternate</i>)
Tata Consulting Engineers Limited, Mumbai	SHRI S. M. PALEKAR SHRI S. KRISHNA (<i>Alternate</i>)
In personal capacity (Grace Villa, Kadamankulam P.O., Thiruvalla 689 583)	SHRI JOSE KURIAN
In personal capacity (A2B/37A, Ekta Apartments, Paschim Vihar, New Delhi 110 063)	SHRI ARVIND KUMAR
In personal capacity (Flat No. 220, Ankur Apartments, Mother Dairy Road, Patparganj, Delhi 110 092)	DR V. THIRUVENGADAM
In personal capacity (K-L/2, Kavi Nagar, Ghaziabad 201 002)	DR A. K. MITTAL
In personal capacity (House No. 2103 Sector 7D, Faridabad 121 006)	SHRI HARISH KUMAR JULKA
In personal capacity (EA-92, Maya Enclave, Hari Nagar, New Delhi)	SHRI R. C. WASON

(Continued from second cover)

- e) Table 1 has been modified to include values for cementitious content.
- f) Galvanized, epoxy coated and stainless steel bars have been permitted for use.
- g) The H/t ratio has been introduced in various design recommendations.
- h) Factor of safety against uplift has been enhanced.
- j) The clause on 'Joints' has been renamed to 'Design, detailing and workmanship of joints' and enlarged to include detailed guidance regarding the types, spacing and making of the joints. Additionally, new figures showing induced contraction joint and water bars on the soffit of the floors in various types of movement joints, and sub-clauses on joints in ground slabs, walls and roofs have been included.
- k) Existing sub-clause on 'Jointing materials' has been made into a new clause to give due emphasis to the topic with the revised content.
- m) Enabling provisions for the use of hydrophilic water-bars and polyurethane grout have been included.
- n) Clause on 'Test of structure' has been revised to provide better guidance.
- p) Title of the standard has been modified to address the actual coverage.

In the formulation of this standard, assistance has been derived from BS 8007 : 1987 'Code of practice for design of concrete structures for retaining aqueous liquids', British Standards Institute.

The composition of the Committee responsible for the formulation of this standard is given in Annex B.

For the purpose of deciding whether a particular requirement of this standard is complied with the final value, observed or calculated, expressing the result of a test or analysis shall be rounded off in accordance with IS 2 : 1960 'Rules for rounding off numerical values (*revised*)'. The number of significant places retained in the rounded off value should be the same as that of the specified value in this standard.

Bureau of Indian Standards

BIS is a statutory institution established under the *Bureau of Indian Standards Act, 2016* to promote harmonious development of the activities of standardization, marking and quality certification of goods and attending to connected matters in the country.

Copyright

BIS has the copyright of all its publications. No part of these publications may be reproduced in any form without the prior permission in writing of BIS. This does not preclude the free use, in the course of implementing the standard, of necessary details, such as symbols and sizes, type or grade designations. Enquiries relating to copyright be addressed to the Director (Publications), BIS.

Review of Indian Standards

Amendments are issued to standards as the need arises on the basis of comments. Standards are also reviewed periodically; a standard along with amendments is reaffirmed when such review indicates that no changes are needed; if the review indicates that changes are needed, it is taken up for revision. Users of Indian Standards should ascertain that they are in possession of the latest amendments or edition by referring to the latest issue of 'BIS Catalogue' and 'Standards: Monthly Additions'.

This Indian Standard has been developed from Doc No.: CED 02 (13638).

Amendments Issued Since Publication

Amend No.	Date of Issue	Text Affected

BUREAU OF INDIAN STANDARDS

Headquarters:

Manak Bhavan, 9 Bahadur Shah Zafar Marg, New Delhi 110002
Telephones: 2323 0131, 2323 3375, 2323 9402

Website: www.bis.gov.in

Regional Offices:

	Telephones
Central : Manak Bhavan, 9 Bahadur Shah Zafar Marg NEW DELHI 110002	{ 2323 7617 2323 3841
Eastern : 1/14 C.I.T. Scheme VII M, V.I.P. Road, Kankurgachi KOLKATA 700054	{ 2337 8499, 2337 8561 2337 8626, 2337 9120
Northern : Plot No. 4-A, Sector 27-B, Madhya Marg CHANDIGARH 160019	{ 265 0206 265 0290
Southern : C.I.T. Campus, IV Cross Road, CHENNAI 600113	{ 2254 1216, 2254 1442 2254 2519, 2254 2315
Western : Manakalaya, E9 MIDC, Marol, Andheri (East) MUMBAI 400093	{ 2832 9295, 2832 7858 2832 7891, 2832 7892

Branches : AHMEDABAD. BENGALURU. BHOPAL. BHUBANESHWAR. COIMBATORE.
DEHRADUN. DURGAPUR. FARIDABAD. GHAZIABAD. GUWAHATI.
HYDERABAD. JAIPUR. JAMMU. JAMSHEDPUR. KOCHI. LUCKNOW.
NAGPUR. PARWANOO. PATNA. PUNE. RAIPUR. RAJKOT. VISAKHAPATNAM.

Published by BIS, New Delhi